

ULI-242T BB-232HESP
ULI-244TI BB-HESP4DR
ULI-244T BB-422HESP
ULI-246T BB-485HESP

3-Stage RS-232/422/485 Serial Surge Suppressors



Features

- Three stages of protection on every data line:
 - 1) Gas discharge tube
 - 2) Series resistor
 - 3) Transient voltage suppressor
- Protected signal ground connection
- Rugged terminal block connections
- Dedicated chassis ground lugs



Introduction

These three-stage surge suppressors protect against lightning strikes and other voltage disturbances with three stages of protection for each line: a gas discharge tube followed by a series resistor and finally a Transient Voltage Suppressor (TVS). The devices are housed in rugged enclosures with a protected signal ground connection and dedicated chassis ground lugs. In order to work properly, it is important to have a good connection between the #1 screws and a solid earth ground.

Specifications

Serial Interface

Model:	Line Connectors:	Equipment Connectors:	Interfaces:
ULI-242T	Terminal blocks	Terminal blocks	RS-232
ULI-244TI			RS-422, RS-485
ULI-244T			
ULI-246T			RS-485

Isolation & Surge Suppression

Model:	Clamping Voltage - Stage 1:	Series Resistance - Stage 2:	Clamping Voltage - Stage 3:	Clamping Time:	Lines Protected:
ULI-242T*	72 Vdc, min. 108 Vdc, max.	2.7 Ohms	14.3 Vdc, min. 15.8 Vdc, max.	< 5 x 10 ⁹ seconds	5
ULI-244TI#			6.4 Vdc, min. 7.14 Vdc, max.		3
ULI-244T*					
ULI-246T*					

*2 terminal posts and 2 metal mounting brackets provide a good ground connection.
 #1 terminal post provides a good ground connection.

Mechanical

Model:	Enclosure:	Dimensions, mm:	Mounting:	Weight, gm
ULI-242T	Metal	114 x 84 x 46	Panel	190
ULI-244TI	Plastic	35.5 x 78.8 x 105.3	DIN rail	114
ULI-244T	Metal	114 x 84 x 46	Panel	190
ULI-246T				

Environmental

Model:	Operating Temperature:	Storage Temperature:	Operating Humidity:
ULI-242T	0 to +70 °C	-40 to +85 °C	0 to 95%, non-condensing
ULI-244TI	-40 to +80 °C		
ULI-244T	0 to +70 °C		
ULI-246T			

Mean Time Between Failures (MTBF)

Calculation Method MIL217F Parts Count Reliability Prediction

Model:	Hours:
ULI-242T	7522077
ULI-244TI	862813
ULI-244T	6976322
ULI-246T	4664831

Regulatory / Approvals / Certifications

- FCC, CE (all models)

Model:	CE Standards	CE Directives
ULI-242T	2014/30/EU – Electromagnetic Compatibility Directive 2011/65/EU – amended by (EU) Reduction of Hazardous Substance Directive (RoHS) Waste Electrical and Electronic Equipment (WEEE)	EMC: EN 55032 Class B – Electromagnetic Compatibility of Multimedia Equipment – Emission Requirements EN 55024 – Information Technology Equipment – Immunity Characteristics – Limits and Methods of Measurement
ULI-244T		
ULI-246T		
ULI-244TI		EMC: EN 55011:2016+A2:2021 Class A Group 1 BS EN 55011:2016+A2:2021 Class A Group 1 CISPR 11:2015+AMD1:2016+AMD2:2019 Ed 6.2 Class A Group 1 EN 55032:2015+A1:2020 Class A / BS EN 55032:2015+A1:2020 Class A CISPR 32:2015+AMD1:2019 Class A EN IEC 61000-6-4:2019 / BS EN IEC 61000-6-4:2019 EN 55035:2017+A11:2020 / BS EN 55035:2017+A11:2020 EN IEC 61000-6-2:2019 / BS EN IEC 61000-6-2:2019 EN 61000-4-2:2009 / EN IEC 61000-4-3:2020 / EN 61000-4-8:2010 Reduction of Hazardous Substance Directive (RoHS) Waste Electrical and Electronic Equipment (WEEE)

Dimensions - ULI-242T, ULI-244TI, ULI-246T

Unit = mm

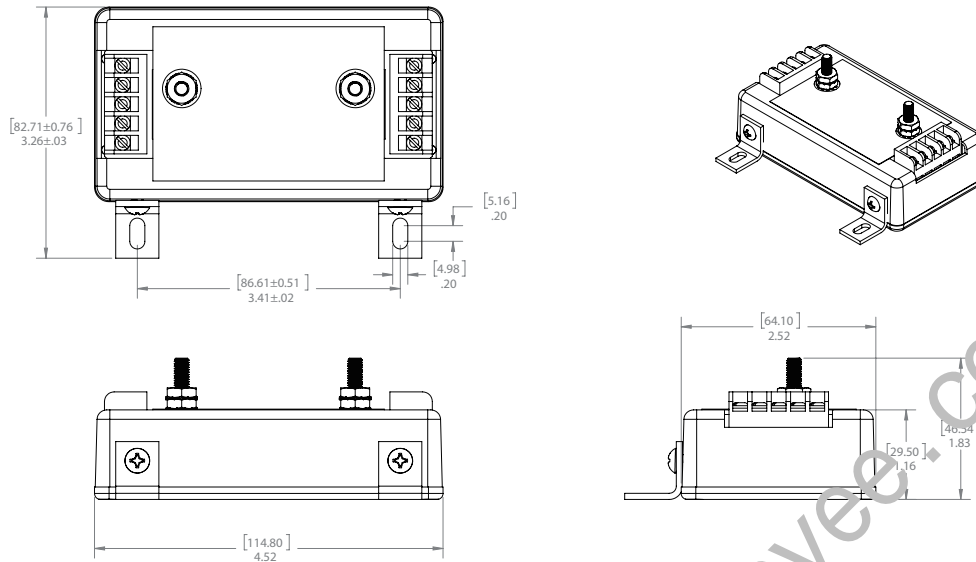

Dimensions - ULI-244TI

Unit = mm

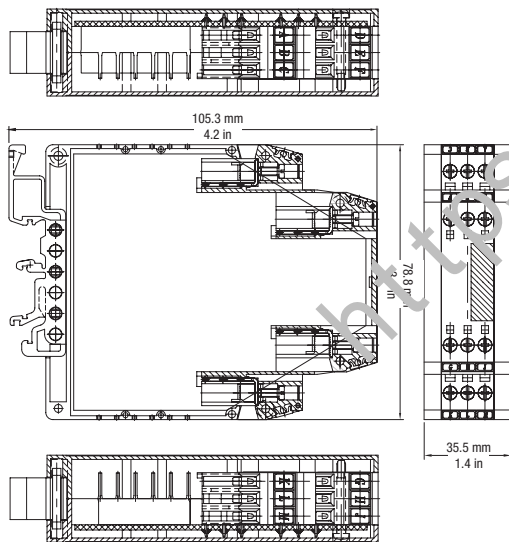

Ordering Information

Model	Part Number to Order	Description
ULI-242T	BB-232HESP	3-stage RS-232 Surge Suppressor, 5 Protected Lines, Panel Mount.
ULI-244TI	BB-HESP4DR	3-stage RS-422/485 Surge Suppressor, 5 Protected Lines, Wide Temperature, DIN Rail Mount.
ULI-244T	BB-422HESP	3-stage RS-422/485 Surge Suppressor, 5 Protected Lines, Panel Mount.
ULI-246T	BB-485HESP	3-stage RS-485 Surge Suppressor, 3 Protected Lines, Panel Mount.

ULI-240 Series Selection Guide

3-Stage RS-232/422/485 Serial Surge Suppressors



Common Features

- Three stages of protection on every data line:
 - 1) Gas discharge tube
 - 2) Series resistor
 - 3) Transient voltage suppressor
- Protected signal ground connection
- Rugged terminal block connections
- Dedicated chassis ground lugs

Surge Suppressor Comparison Table

Model Number	ULI-242T	ULI-244T	ULI-244TI	ULI-244TI
Part Number to Order	BB-232HESP	BB-422HESP	BB-485HESP	BB-HESP4DR
Description	3-Stage Surge Suppressors			
Key Features	Rugged Metal Case, Panel Mount			DIN Rail Mount, Plastic Case, Wide Operating Temperature
Serial Protocol	RS-232	RS-422/485	RS-485	RS-422/485
Serial Line Connectors	Terminal blocks			
Equipment Line Connectors	Terminal blocks			
Stage 1: Clamping Voltage	7.2 to 108 Vdc (min./max.)			
Stage 2: Series Resistance	2.7 Ohms			
Stage 3: Clamping Voltage	14.3 - 15.8 Vdc (min./max.)	6.45 - 7.14 Vdc (min./max.)		
Clamping Time	Less than 5 x 10 ⁹ seconds			
Lines Protected	5		3	5
Enclosure	Metal			Plastic
Dimensions, mm	114 x 84 x 46			35.5 x 78.8 x 105.3
Mounting Installation	Panel			DIN rail
Operating Temperature	0 to +70 °C			-40 to +80 °C
MTBF (MIL217F), hours	7522077	6976322	4664831	862813
Regulatory/Approvals/Certifications	FCC, CE, ECD, RoHS, WEEE EMC: EN 55032 Class B – Electromagnetic Compatibility of Multimedia Equipment – Emission Requirements EN 55024 – Information Technology Equipment – Immunity Characteristics – Limits and Methods of Measurement			EMC: EN 55011:2016+A2:2021 Class A Group 1 BS EN 55011:2016+A2:2021 Class A Group 1 CISPR 11:2015+AMD1:2016+AMD2:2019 Ed 6.2 Class A Group 1 EN 55032:2015+A1:2020 Class A / BS EN 55032:2015+A1:2020 Class A CISPR 32:2015+AMD1:2019 Class A EN IEC 61000-6-4:2019 / BS EN IEC 61000-6-4:2019 EN 55035:2017+A11:2020 / BS EN 55035:2017+A11:2020 EN IEC 61000-6-2:2019 / BS EN IEC 61000-6-2:2019 EN 61000-4-2:2009 / EN IEC 61000-4-3:2020 / EN 61000-4-8:2010