

# WebOP-110K

## 10.1" WSVGA Operator Panel Installed with WebAccess/HMI Software



CE FCC

### Features

- ARM9™ 32-bit, 300 MHz RISC processor with 128 MB flash memory
- Includes a RTC battery backup RAM 128KB
- Supports runtime data downloads through serial, Ethernet, and USB interfaces
- Supports brightness controls via touch panel
- Reliable firmware for 24/7 operation
- Supports the WebAccess/HMI Designer development tool on Windows XP/Vista/7/10
- Supports operation in both landscape and portrait mode
- Supports over 450 PLC industrial communication protocols
- Panel mount design ensures easy installation
- IP65-rated front panel

### Introduction

To fulfill the stringent standards of the automation market, especially for packaging, label slitting, and robot disposition applications, Advantech developed the WebOP-100 series for diverse operations that involve PLCs, motion/thermal controllers, inverters, and sensors. Powered by an ARM9™ 32-bit, 300 MHz RISC processor with 128 MB flash memory, the WebOP-100 series systems are available with LCDs of varying size (from 4.3 to 15"). Additionally, WebOP-100 systems are bundled with Advantech's WebAccess/HMI software – a web browser-based human-machine interface designed for HMI applications to reduce labor and improve manufacturing efficiency through visualization.

### Specifications

#### General

- **Certification** CE, FCC Class A
- **Dimensions (W x H x D)** 270.8 x 212.8 x 40.5mm (10.66" x 8.38" x .59")
- **Cutout Dimensions** 259 x 201mm (10.20" x 7.91")
- **Front Panel Thickness** 6 mm (0.23 in)
- **Operating System** HMI RTOS, WebAccess/HMI Designer
- **Power Supply Voltage** 24V<sub>DC</sub> ±10%
- **Power Consumption** 20W
- **Enclosure Housing** Plastic
- **Mount Options** Panel
- **Weight (Net)** 1.1 kg (2.3 lbs)

#### System Hardware

- **CPU** ARM9™ 32-bit, 300 MHz RISC processor
- **Battery Backup Memory** 128KB
- **Flash Memory** 128M NAND flash

#### Communication Interface

- **COM1** RS-232 (DB9 Female)
- **COM2** RS-422/485 (DB9 Female)
- **COM3** RS-485 (DB9 Female)
- **Ethernet (RJ45)** 10/100 BaseT (for NAE model)
- **I/Os** 1 x USB (Client)  
1 x USB (Host)

#### LCD and Touchscreen

- **Display Type** WSVGA TFT LCD
- **Display Size** 10.1"
- **Max. Resolution** 1024 x 600
- **Max. Colors** 65,536 colors
- **Luminance (cd/m<sup>2</sup>)** 350
- **Backlight Life** LED, 20,000 hr
- **Touchscreen** 4 wires analog resistive

#### Environment

- **Operating Temperature** -10 ~ 60°C (14 ~ 140° F)
- **Storage Temperature** -20 ~ 70°C (-4 ~ 158° F)
- **Humidity** 10 ~ 90% RH @ 40 °C, non-condensing
- **Ingress Protection** Front panel: IP65
- **Vibration Protection** 10 ~ 55Hz (X,Y,Z direction, 1G, 30 minutes shock test)

### Ordering Information

- **WOP-110K-SAE** 10.1" WSVGA, 64MB/128MB, Serial x3
- **WOP-110K-NAE** 10.1" WSVGA, 64MB/128MB, Serial x3, Ethernet

### Optional Accessories

- **PWR-247-CE** 100-240V 60W 24V 2.5A Power Supply
- **1702002600** Power Cable US Plug 1.8 M
- **1702002605** Power Cable EU Plug 1.8 M
- **1702031801** Power Cable UK Plug 1.8 M
- **1700000596** Power Cable China/Australia Plug 1.8 M

Dimensions

Unit: mm

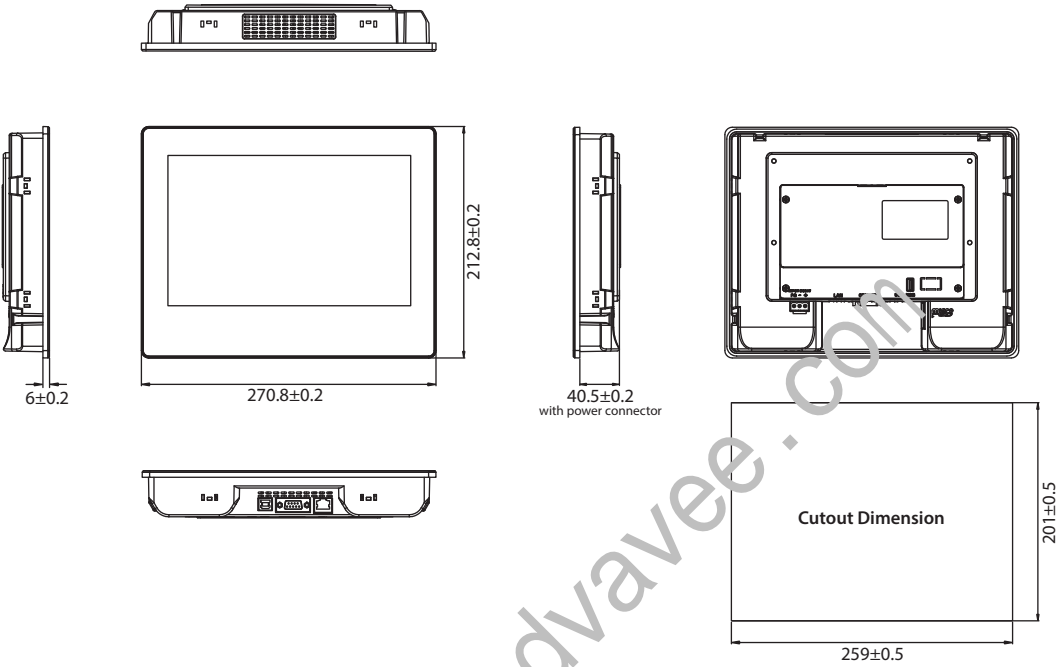

Panel Cutout Dimensions: 259 x 201mm (10.20" x 7.91")

Rear View

WOP-110K-NAE

WOP-110K-SAE

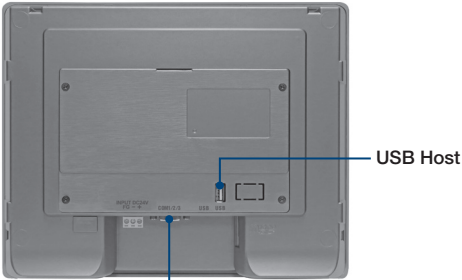
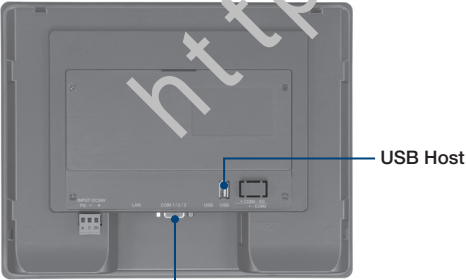

COM1 / COM2 / COM3  
(RS-232 / RS-422/485 / RS-485)

COM1 / COM2 / COM3  
(RS-232 / RS-422/485 / RS-485)

