

WOP-107E

7" WVGA Operator Panel Installed with HMINavi Software



CE FCC

Features

- ARM9™ 32-bit RISC processor with 128 MB SDRAM working memory
- Supports over 500+ PLC industrial communication protocols
- Backup memory 128KB for retaining critical data or parameter
- Supports the HMINavi Designer development tool free on Windows 10
- Supports HMINavi Runtime data downloads through Serial, Ethernet, USB port
- No limitation on the internal I/Os points used for variety application
- Reliable firmware setting from HMINavi software for 24/7 operation
- Easy to switch one application to different LCD sizes in seconds
- Supports operation in both landscape and portrait mode
- Panel mount design ensures easy installation and IP54-rated front panel

Introduction

To fulfill the stringent standards of the automation market, especially for packaging, label slitting, and F&B applications, Advantech developed the WOP-100E series for diverse operations that involve PLCs, thermal controllers, inverters, and sensors. Powered by an ARM9™ 32-bit RISC processor with 128 MB working memory, the WOP-100E series systems are available with LCDs of 7" & 10". Additionally, WOP-100E systems are bundled with Advantech's HMINavi software – a human-machine interface designed for HMI applications to reduce labor and improve manufacturing efficiency through visualization. Powerful connectivity drivers support 500+ variety market brands of PLC.

Specifications

General

- **Certification** CE, FCC Class A
- **Dimensions (W x H x D)** 197.1 x 140.1 x 25.7mm (7.76" x 5.52" x 1.01")
- **Cutout Dimensions** 185 x 128mm (7.28" x 5.04")
- **Front Panel Thickness** 6.2 mm (0.244")
- **Operating System** HMI RTOS, HMINavi Designer
- **Power Supply Voltage** 24V_{DC} ± 10% (NAE: Isolation, SAE: Non-Isolation)
- **Power Consumption** 20W
- **Enclosure Housing** Plastic
- **Mount Options** Panel
- **Weight (Net)** 0.42 kg (0.93 lbs)

System Hardware

- **CPU** ARM9™ 32-bit RISC processor
- **Battery Backup Memory** 128KB
- **Working Memory** 128 MB SDRAM
- **Storage** 128 MB NAND Flash
Runtime Max Size: 64 MB
Data Logger Max Size: 64 MB

Communication Interface

- **COM1** RS-232 (NAE: 9-Pin Terminal, SAE: DB9 Female)
- **COM2** RS-422/485 (NAE: 9-Pin Terminal, SAE: DB9 Female)
- **Ethernet (RJ45)** 10/100 BaseT (for NAE model)
- **I/O** 1 x USB (Client)
1 x USB (Host)

LCD and Touchscreen

- **Display Type** WVGA TFT LCD
- **Display Size** 7"
- **Max. Resolution** 800 x 480
- **Max. Colors** 16,777,215 colors (24bit)
- **Luminance (cd/m²)** 300
- **Backlight Life** LED, 20,000 hr
- **Touchscreen** 4 wires analog resistive

Environment

- **Operating Temperature** 0 ~ 50°C (32 ~ 122° F)
- **Storage Temperature** -10 ~ 60°C (14 ~ 140° F)
- **Humidity** 95% RH @ 40°C, non-condensing
- **Ingress Protection** Front panel: IP54
- **Vibration Protection** 5 ~ 500Hz (X,Y,Z direction, 1Grms, 1hour per axis)

Ordering Information

- **WOP-107E-SAE** 7" WVGA, 128MB, 128MB(NAND), Serial x2
- **WOP-107E-NAE** 7" WVGA, 128MB, 128MB(NAND), Serial x2, Ethernet

Optional Accessories

- **96PSD-A60W24-MM** A/D 100-240V 60W 24V MDR DIN RAIL
- **96PSD-A120W24-MN** A/D 100-240V 120W 24V NDR DIN RAIL

Dimensions

Unit: mm

WOP-107E-NAE

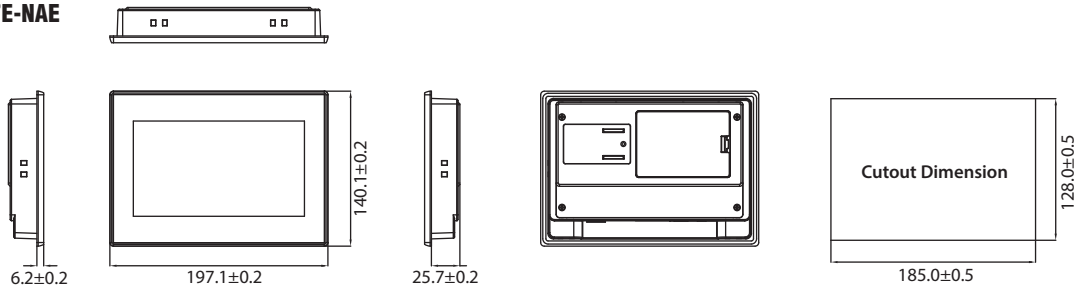

WOP-107E-SAE

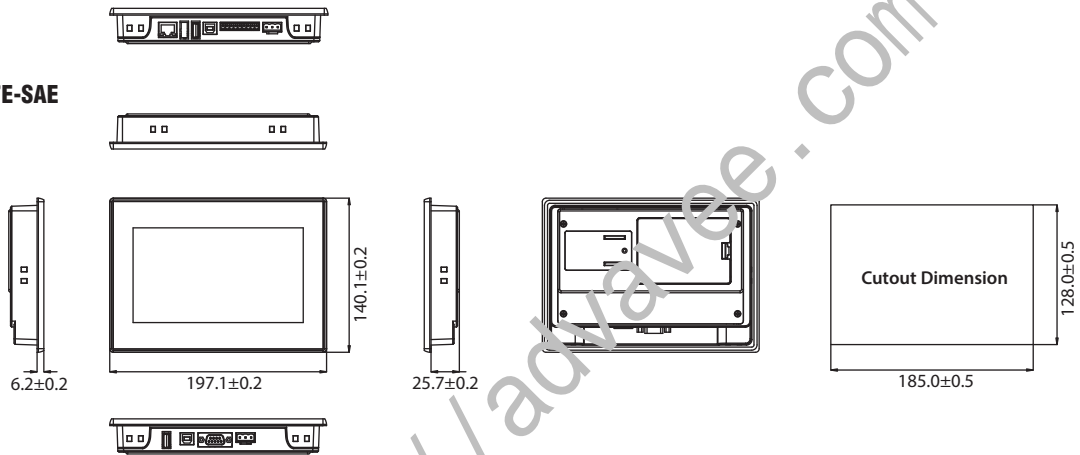

Panel Cutout Dimensions: 185 x 128mm (7.28" x 5.04")

Rear View

WOP-107E-NAE



WOP-107E-SAE

