

TPC-312 TPC-315 TPC-317

Touch Panel Computer with 8th Gen. Intel® Core™ i3/ i5/ i7 Processor, built-in 8G DDR4 RAM



Features

- 8th Gen. Intel® Core™ i3- 8145UE dual-core/ i5-8365UE quad-core/ i7-8665UE quad-core processor with built-in 8 GB DDR4 SO-DIMM
- Dual channel memory slots support up to 64G in total
- Compact, fanless embedded system with aluminum alloy front bezel and chassis grounding protection
- True-flat touchscreen with 5-wire resistive touch control and IP66-rated front panel
- Support expansion via Full-size Mini PCIe and two M.2 slots (NVMe, 5G)
- Diverse system I/O and isolated digital I/O via iDoor technology
- Support fieldbus protocols/GPS/GPRS/Wi-Fi capabilities via iDoor technology
- Support TPM2.0 hardware security

Introduction

TPC-3xx touch panel computer is equipped with TFT LCD, low-power 8th Gen. Intel® Core™ i3- 8145UE dual-core/ i5-8365UE quad-core/ i7-8665UE quad-core processor, and built-in 8 GB DDR4 SO-DIMM delivering high performance yet compact and fanless computing system. To provide enhanced durability and satisfy diverse applications of industrial automation, TPC-3xx features IP66-rated front panel protecting against dust and water ingress, and two extra expansion M.2 M Key, B Key slots supporting NVMe, SATA or 5G application. With Advantech's iDoor technology integrated via mini PCIe slot for function expansion: such as additional I/O ports, isolated digital I/O, fieldbus protocols, GPS/GPRS/Wi-Fi communication and MRAM. The integrated DP and audio ports allow a secondary monitor and speakers to be attached for increased functionality.

Specifications

General

- BIOS**: AMI UEFI
- Certification**: BSMI, CCC, CE, FCC Class A, CB/UL
- Cooling System**: Fanless design
- Dimensions (W x H x D)**: 12.1": 311.8 x 238 x 67 mm (12.28 x 9.37 x 2.64 in)
15": 383.2 x 307.3 x 66.5 mm (15.09 x 12.10 x 2.62 in)
17": 410.4 x 343.4 x 68 mm (16.16 x 13.52 x 2.68 in)
- Enclosure**: Front bezel: Die cast aluminum alloy
Back housing: Die cast aluminum alloy
- Mounting**: VESA Mount, Desktop, Wall or Panel Mount
- OS Support**: Win 10, Android, Linux
- Security**: TPM 2.0 (built-in)
- Power Consumption**: 12.1": 41.06W (Typical)
15": 36.79W (Typical)
17": 45.48W (Typical)
- Power Input**: 24 V_{DC} ± 20%
- Watchdog Timer**: 15-255 sec (system)
- Weight (Net)**: 12.1": 4.1kg (9.04lbs)
15": 5.8kg (12.79lbs)
17": 6.1kg (13.45lbs)

System Hardware

- CPU**: Intel 8th Gen. Whiskey Lake
i3-8145UE 2.20 GHz Dual-core
i5-8365UE 1.60 GHz Quad-core
i7-8665UE 1.70 GHz Quad-core
- Memory**: Dual channel DDR4 SO-DIMM (Each channel supports up to 32G)
1 x 8G DDR4 SO-DIMM (Built-in)
- LAN**: 2 x 10/100/1000BASE-T (A ver.) or 2.5GbE (B ver.)
- Expansion Slot**: 1 x Full-size mini PCIe(PCle/USB2.0)
1 x SIM (Optional 4G/5G module)

- Storage Slot**: 1 x M.2 M key 2280 (SATA or NVMe PCIe4)
1 x M.2 B Key 2242 (SATA)
3042, 3052 (PCIe/USB3.0 for 4G/5G module)
1 x 2.5" SSD/ HDD (SATA, Max. 7mm)
- I/O**: 2 x RS-232/422/485
1 x USB 2.0
4 x USB 3.2 (Gen 2)
1 x iDoor slot
1 x Displayport (Video output)
1 x Audio line out/ mic in

LCD Display

	TPC-312	TPC-315	TPC-317
Display Type	XGA TFT LED LCD	XGA TFT LED LCD	SXGA TFT LED LCD
Display Size	12.1" (4:3)	15" (4:3)	17" (4:3)
Max. Resolution	1024 x 768	1024x768	1280 x 1024
Max Colour	16.2M	16.2M	16.7M
Luminance cd/m²	300	300	300
Viewing Angle (H/V°)	178°/178°	176°/176°	160°/140°
Backlight Life	50,000 hrs	70,000hrs	50,000 hrs
Contrast Ratio	1000:1	2000:1	800:1

Touchscreen

- Lifespan**: 36 million touches at a single point
- Light Transmission**: Above 75%
- Resolution**: Linearity
- Type**: 5-wire resistive : TPC-312/TPC-315/TPC-317

Environment

- **Relative Humidity** Operating, 95% RH @ 40° C, Non-Condensing
Non-Operating, 95% RH @ 60° C, Non-Condensing
- **Ingress Protection** IP66-rated front panel
- **Operating Temperature** -10~55°C (14~131°F) (w/o air flow)
- **Storage Temperature** -20~70°C (-4~158°F)
- **Vibration Protection** With SSD: 1 Grms (5 ~ 500 Hz)
(Operating, random vibration)

Rear View

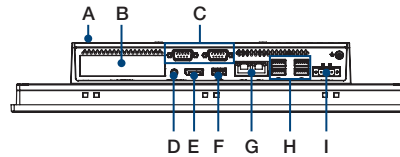

- A. Default HDD/SSD Bay
- B. iDoor slot
- C. RS-232/422/485
- D. Audio line out/ mic in
- E. Display Port
- F. USB 2.0
- G. LAN (Left: 1GbE, Right: 2.5GbE)
- H. USB 3.2 (Gen 2)
- I. Power Receptor

Dimensions

Unit: mm

TPC-312

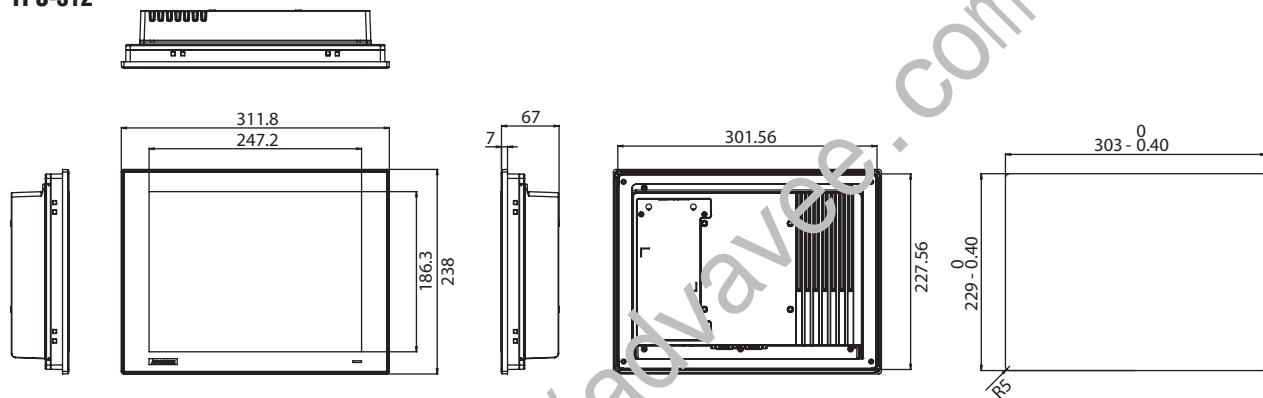

TPC-312 Panel Cutout Dimensions: 303 x 229 mm (11.93 x 9.02 in)

TPC-315

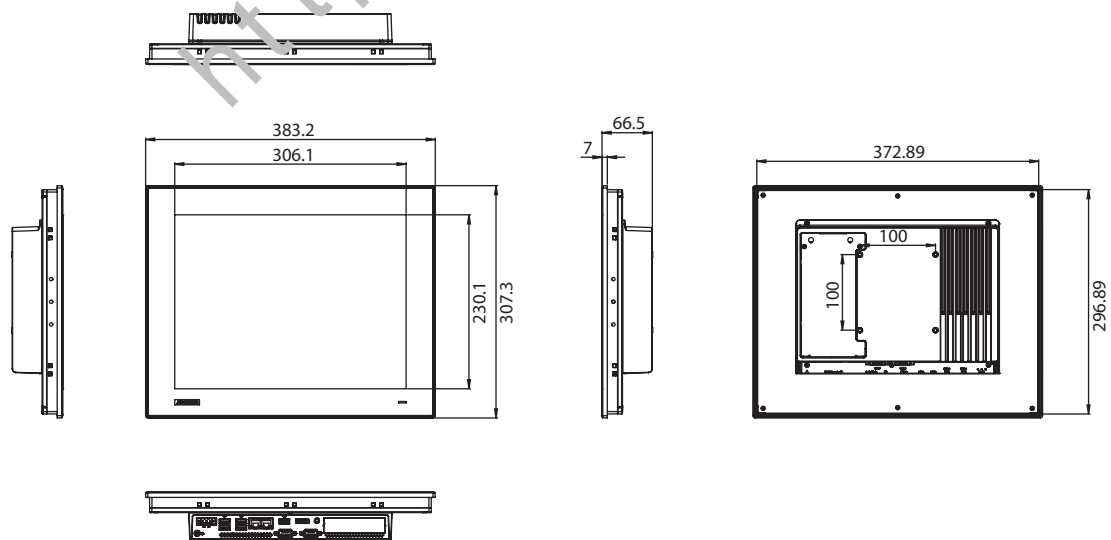

TPC-315 Panel Cutout Dimensions: 374.5 x 298.5 mm (14.74 x 11.75 in)

Dimensions

Unit: mm

TPC-317

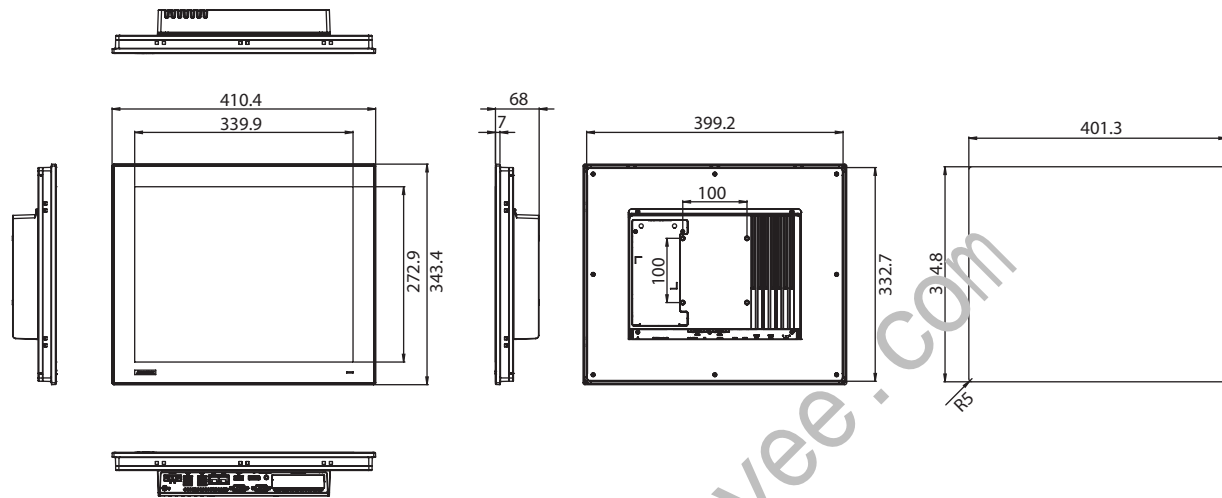

TPC-317 Panel Cutout Dimensions: 401.3 x 334.8 mm (15.80 x 13.18 in)

Ordering Information

- **TPC-312-R833B** 12.1" XGA Panel PC, Intel® Core™ i3-8145UE 2.20GHz Dual-core Processor, 8G DDR4 RAM
- **TPC-312-R853B** 12.1" XGA Panel PC, Intel® Core™ i5-8365UE 1.60GHz Quad-core Processor, 8G DDR4 RAM
- **TPC-312-R873B** 12.1" XGA Panel PC, Intel® Core™ i7-8665UE 1.70GHz Quad-core Processor, 8G DDR4 RAM
- **TPC-315-R833B** 15" XGA Panel PC, Intel® Core™ i3-8145UE 2.20GHz Dual-core Processor, 8G DDR4 RAM
- **TPC-315-R853B** 15" XGA Panel PC, Intel® Core™ i5-8365UE 1.60GHz Quad-core Processor, 8G DDR4 RAM
- **TPC-315-R873B** 15" XGA Panel PC, Intel® Core™ i7-8665UE 1.70 GHz Quad-core Processor, 8G DDR4 RAM
- **TPC-317-R833B** 17" SXGA Panel PC, Intel® Core™ i3-8145UE 2.20GHz Dual-core Processor, 8G DDR4 RAM
- **TPC-317-R853B** 17" SXGA Panel PC, Intel® Core™ i5-8365UE 1.60GHz Quad-core Processor, 8G DDR4 RAM
- **TPC-317-R873B** 17" SXGA Panel PC, Intel® Core™ i7-8665UE 1.70GHz Quad-core Processor, 8G DDR4 RAM

Optional Accessories

- **96PSA-A120W24T2-4** 120W 24V_{DC} power supply
- **1702002600** Power cable (US) 1.8 M
- **1702002605** Power cable (EU) 1.8 M
- **1702031801** Power cable (UK) 1.8 M
- **1700000596-11** Power cable (China/Australia) 1.8 M
- **PPC-STAND-A1E** Stand For HMI Series
- **PPC-ARM-A03** ARM VESA Standard (A-CLEVER)
- **PPC-174T-WL-MTE** Wall mount kit A800B for HMI

Embedded OS

- **20704WX1HS0006** Img WIN10 LTSC V6.08 B018 TPC-300 High
- **20704WX1VS0006** Img WIN10 LTSC V6.08 B018 TPC-300 Value
- **20703LEB1S0091** Image AdvLinuxTu V2.0.6 for UNO/TPC series
- **Coming Soon** Android

Note : Compatible with both A and B versions

iDoor Modules

- **PCM-24D2R2-BE** Isolated RS-232, DB9 x 2, (USB type)
- **PCM-24D2R4-BE** Isolated RS-422/485, DB9 x 2, (USB type)
- **PCM-24D4R2-BE** Non-Isolated RS-232, DB37 x 1 (USB Type)
- **PCM-24D4R4-BE** Non-Isolated RS-422/485, DB37 x 1 (USB Type)
- **PCM-27D24DI-AE** Digital I/O, 16 DI / 8 DO, Isolation, DB37 x 1
- **PCM-24R2GL-AE** 2 Port Giga LAN Intel i350 PCIe mini card
- **PCM-24R2PE-AE** Intel i350, GbE, PoE IEEE 802.3af, PD, RJ45 x 2
- **PCM-24U2U3-BE** PCM-24U2U3, 2-Port USB 3.0, mPCIe
- **PCM-24S2WF-CE** 802.11 a/b/g/n/ac 2T2R w/BT4.1, Intel AC9260
- **PCM-23C1CF-CE** 1 slot Cfast iDoor for CFast with PWR cable
*(1700033614-01 the CFast Power cable for PCM-23C1CF-CE)
- **PCM-23U1DG-CE** Internal locked USB Slot for USB Dongle, mPCIe
- **PCM-26D2CA-BE** SJA1000 CANBus, Lattice, CANOpen, DB9 x 2
- **PCM-26D2CA-CE** USB CANBus, CANOpen, DB9 x 2

Application Software

WebAccess/SCADA	Advantech WebAccess/SCADA is a 100% browser-based IIoT software platform aimed at supervisory control and data acquisition (SCADA) operations. WebAccess/SCADA provides open interfaces that allow our customers and partners to develop unique IoT applications for different vertical markets. In addition to supporting traditional SCADA functions, the platform features an HTML5-based user interface and intelligent dashboard to facilitate cross-platform, cross-browser data analysis. Moreover, WebAccess/SCADA not only offers built-in widgets, but is also equipped with an innovative Widget Builder that enables customers to build their own widgets.
WebAccess/HMI	Advantech WebAccess/HMI is human-machine interface (HMI) software based on Microsoft's Windows operating system. This software features excellent communication and monitoring capabilities, supports more than 350 PLC communication protocols, and offers a wide choice of screen design objects to satisfy diverse integrations of factory automation and HMI operation and monitoring requirements.

Packing List

Item	Part No.	Description	Qty
Grounding cable	1703011001-11	A Cable G-TEM 4.3 1.0CM C GR/Y	1pcs
Plug-In Block	1652007930-01	Plug-In Block 1x3P 5.08mm/PA66/F/VA	1pcs
Manual	2003031200	User_Manual(EN)_TPC-300_Seires_B510 1st	1pcs
Warranty	2190000902	CARDBOARD-WARRANTY REV. A2	1pcs
VESA Screw	1930005204	Screw M4x10 L R/S DH=6.8x2.50 + ST ZBK PL	4pcs
HDD Screw	1930001361	Screw M3x4L S/S D=5 H=1.2 (2+) ST Ni NK	4pcs
M.2 Screw	1930008738	Screw M3x3L F/S D=5 H=1 2+ ST Ni NK	1pcs
DRAM Thermal Pad	1990020119N001	Thermal Pad 59x24.2x3.0mm XR-HL K=1.2 TP Sarcon	1pcs
Clamp	1962055040	CLAMPER PPC-55 M1632611 A2	8pcs : TPC-312 10pcs : TPC-315 / TPC-317
Clamp Screw	1935042520	Screw M4x25L R/S D=8.3 H=2.5 (2+) ST BZn	8pcs : TPC-312 10pcs : TPC-315 / TPC-317
China RoHS	202KAKM030	China rohs for AKMC model name 1st ed	1pcs

Please note: If some optional modules are offered with the system, additional system certificates may be required in certain regions/countries. Please contact Advantech for certificate compliance.