

SPC-515

15" XGA TFT LED LCD Industrial Multi-Touch Panel PC with Stainless Steel Housing and IP69K Rating

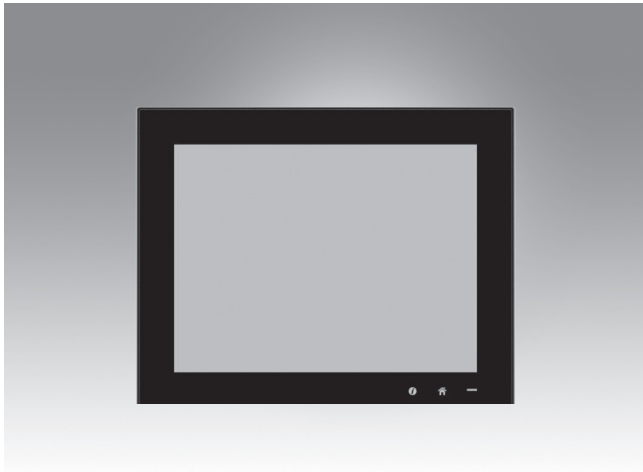

Features

- All-around IP69K rating protects against dust and water
- 304L stainless steel housing
- 6th generation Intel® Core™ i3 processor
- Touchscreen equipped with shatter protection film
- PCAP multi-touch control
- Built-in function and home keys for intuitive operation
- Fanless cooling system
- Airflow valve design reduces condensation caused by temperature changes

Introduction

The SPC-515 is a 15" multi-touch panel PC with a fully sealed, IP69k-rated 304L stainless steel housing, making it suitable for the food & beverage and pharmaceutical industries. Equipped with a 6th generation Intel® Core™ i3 processor that delivers high-performance computing, SPC-515 can be deployed as a data visualization gateway or control panel. The glass touchscreen is enhanced with shatter protection film that eliminates the potential for broken glass to cause safety hazards or food contamination issues. Moreover, the panel PC is compliant with EN 1672-2 specifications, ensuring adequate hygiene for food processing applications.

Specifications

General

- **BIOS** AMI UEFI
- **Certification** IP69k, CE, FCC Class A, UL
- **Cooling System** Fanless design
- **Dimensions (W x H x D)** 389.6 x 313.7 x 56 mm (15.33 x 12.34 x 2.2 in)
- **Enclosure** Front: 304L Stainless steel
Back: 304L Stainless steel
- **Mount Options** VESA
- **Power Consumption** 60 W
- **Power Input** 21 ~ 27 V_{DC}
- **Weight** 10 kg (22.04 lb)
- **OS Support** Windows 10

System Hardware

- **CPU** Intel® i3-6100U, 2.3GHz
- **Memory** 8 GB DDR3L SODIMM (up to 16 GB)
- **Expansion Slots** 2 x Full-size mini PCIe x1
- **Storage** 2.5" SATA x1, default equipped with 128GB
- **LAN** 2 x 10/100/1000 BASE-T (M12 connector, A-coding, 8-pin female)
- **I/O** 1 x RS-232 (M12 connector, A-coding, 8-pin male)
2 x USB 2.0 (M12 connector, A-coding, 8-pin female)
1 x Power input 24 V_{DC} (M12 connector, A-coding, 5-pin male)

LCD

- **Display Type** XGA TFT LED LCD
- **Display Size** 15"
- **Max. Resolution** 1024 x 768
- **Max. Colors** 16.7M
- **Luminance (cd/m²)** 300 cd/m²
- **Viewing Angle (H/V)** 176 / 176
- **Backlight Life** 70,000 hr

Touchscreen

- **Light Transmission** 90% ± 3%
- **Treatment** Anti-glare film (shatter protection)
- **Touch Type** Projected capacitive

Environment

- **Humidity** 10 ~ 95% RH @ 40 °C, non-condensing
Note: Tested for 48 hr
- **Operating Temperature** 0 ~ 50 °C (32 ~ 122 °F)
- **Storage Temperature** -20 ~ 60 °C (-4 ~ 140 °F)
- **Vibration Protection** With SSD: 3 Grms (5 ~ 500 Hz)
(Operating, random vibration)

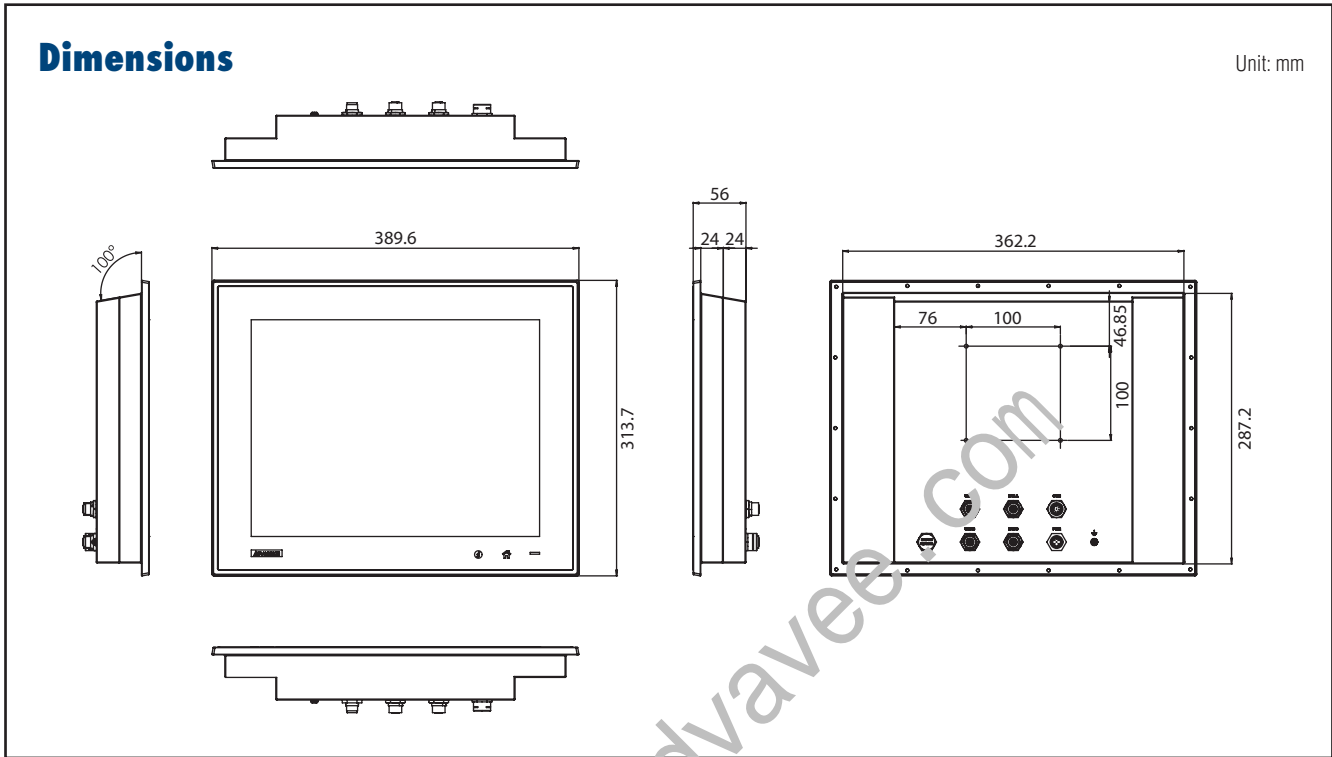

Ordering Information

- **SPC-515-633AE** 15" XGA TFT LCD with PCAP touch control, Intel® i3-6100U processor, and IP69K rating

Optional Accessories

- **1702002600** Power cable US plug 1.8 M
- **1702002605** Power cable EU plug 1.8 M
- **1702031801** Power cable UK plug 1.8 M
- **1700000596** Power cable China/Australia plug 1.8 M
- **98R1SPC5000** M12 cable accessory kit for SPC-515
- **PWR-247-DE** 60 W, 24 V, 2.5A power supply
- **96PSA-A120W24T2** Adapter 100 ~ 240V 120W 24V 5A

Embedded OS

- **20703WX9VS0015** Win 10 LTSC X64 Embedded OS

Rear View

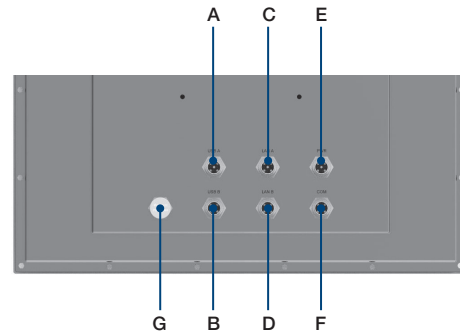

- | | |
|----------|--------------------------|
| A. USB A | E. PWR |
| B. USB B | F. COM |
| C. LAN A | G. Pressure relief valve |
| D. LAN B | |

Please note: If some optional modules are offered with the system, additional system certificates may be required in certain regions/countries. Please contact Advantech for certificate compliance.