

IDS-3210

10.4" Industrial Panel Mount Monitor

NEW



Features

- 10.4" SVGA and XGA LCD panel with LED backlight for 20% power saving and environmental protection
- -20° C ~ +60° C wide range operating temperature
- 5-wire resistive and P-cap touch screen solution or 3mm tempered smudge resistant protected glass
- Combo touch interface: RS-232 and USB
- Dual signal interface with VGA & DVI
- Standard integrated frame
- Versatile mounting methods for front mounting and VESA mounting
- Anti-Reflective treatment (optional)
- Ultra high brightness solution of 1200 cd/m² for outdoor application (optional)

Introduction

The Advantech IDS-3210 Embedded Panel Mount Monitor series offers flexible options for LCD, touchscreen, signal interface and chassis mounting. The series with standard integrated frame design, supports front and VESA mounting which brings the benefits of easy installation and provides flexibility for different applications.

Specifications

	Model	IDS-3210	IDS-3210E	IDS-3210 XGA
Display	Size	10.4" LED panel	10.4" LED panel	10.4" LED panel
	Resolution	800 x 600 (SVGA)	800 x 600 (SVGA)	1024 x 768 (XGA)
	Viewing Angle	80°/80° (H), 60°/70° (V)	80°/80° (H), 60°/70° (V)	88°/88° (H), 88°/88° (V)
	Brightness	400 (cd/m ²)	230 (cd/m ²)	500 (cd/m ²)
	Color Support	16.2M / 262K colors	16.2M / 262K colors	16.2M colors
	Contrast Ratio	700:1	500:1	1000:1
	Response Time	30 [msec]	35 [msec]	25 [msec]
	Backlight Life (hrs)	50,000 hrs	30,000 hrs	50,000 hrs
	Touchscreen	Touchscreen Type	5-Wire Resistive Touchscreen	
Surface Hardness		3H		3H / Mohs 5
Durability		36 million touches		36 million touches / -
Transparency		82%±3%		82% / 90%
Environment	Operating Temperature	-20 ~ 60 °C (-4 ~ 140 °F)	0 ~ 45 °C (32 ~ 113 °F)	-20 ~ 60 °C (-4 ~ 140 °F)
	Storage Temperature	-30 ~ 70 °C (-22 ~ 158 °F)	-20 ~ 60 °C (-4 ~ 140 °F)	-30 ~ 70 °C (-22 ~ 158 °F)
	Humidity	10 ~ 90% @ 40 °C, non-condensing		
System	I/O	VGA x 1; DVI-D x 1; 12 V _{DC} Jack x 1; USB x 1; RS-232 x 1 (USB & RS-232 are reserved for the connection to enable touch usage only)	VGA x 1; 12 V _{DC} Jack x 1; USB x 1; RS-232 x 1 (USB & RS-232 are reserved for the connection to enable touch usage only)	VGA x 1; DVI-D x 1; 12 V _{DC} Jack x 1; USB x 1; RS-232 x 1 (USB & RS-232 are reserved for the connection to enable touch usage only)
	OSD	Keys: menu, up, down, auto adjust, monitor power on/off Menu Functions: brightness, contrast, screen settings, color temp, language OSD settings, VGA/DVI, recall, auto adjust	Keys: menu, up, down, auto adjust, monitor power on/off Menu Functions: brightness, contrast, color adjust, color temp, auto color and language	Keys: menu, up, down, auto adjust, monitor power on/off Menu Functions: brightness, contrast, screen settings, color temp, language OSD settings, VGA/DVI, recall, auto adjust
	Power	36 W power adapter, with AC 100 ~ 240 V input and DC +12 V @ 3 A output		
	EMC Compliance	CE/FCC/CCC		

Dimensions

Unit: mm

IDS-3210 series

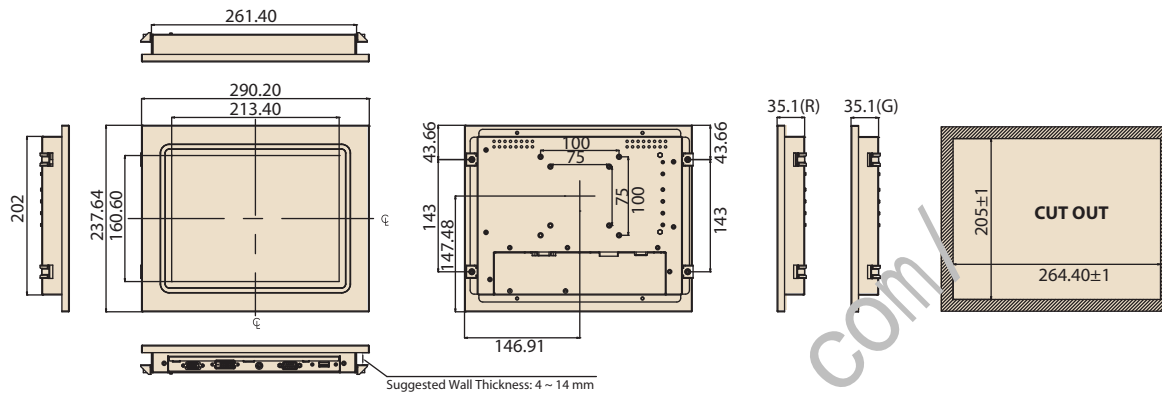

IDS-3210E series

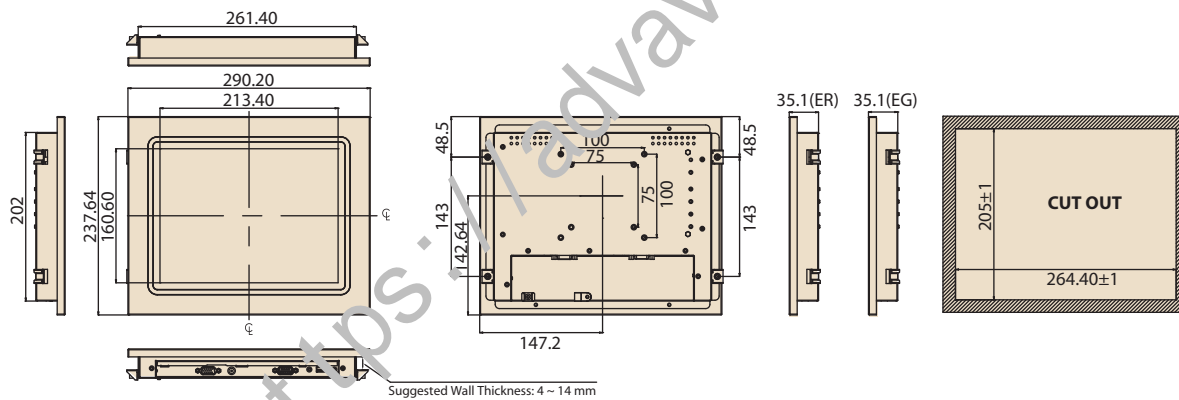

IDS-3210 XGA series with resistive touch screen / glass

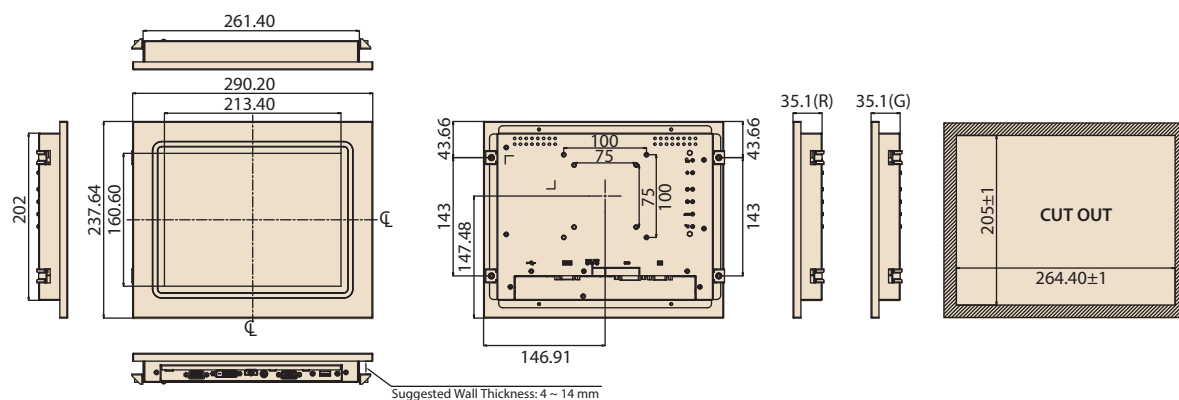

Dimensions

Unit: mm

IDS-3210 XGA series with P-cap touch screen

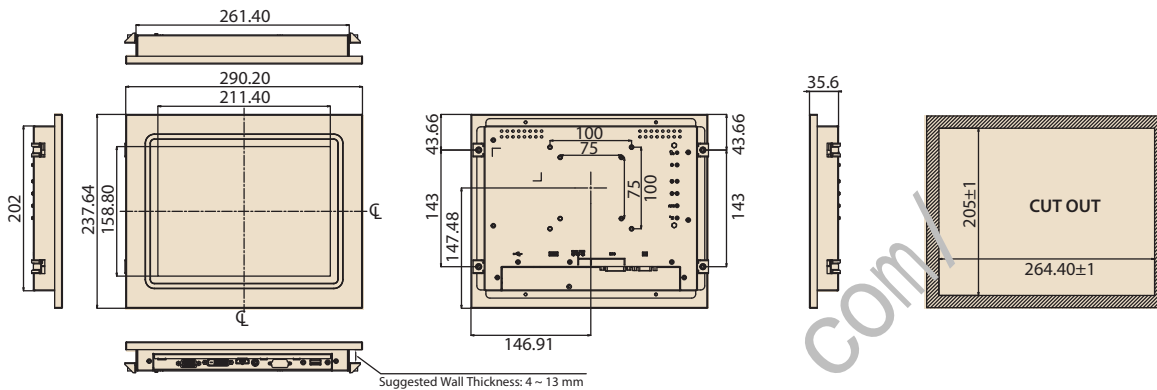

Packing List

Part Number	Description
1700002215	1 x M Cable USB-A(M)/USB-A(M) 180 cm
1700021332-01	1 x VGA cable 15P(M) 180 cm
1962055040	4 x clammer
1935042520	4 x clammer screws M4_25L
1992610005	1 x cable clamp
1933030500	1 x cable clamp screw
1992602010	1 x cable tie

* USB Cable is only included for models with touch screen.
Note: Package contents are subject to change without prior notice

Ordering Information

Model Name	Description
IDS-3210G-40SVA1E	10.4" SVGA 400 cd/m ² LED Panel Mount Monitor
IDS-3210R-40SVA1E	10.4" SVGA 400 cd/m ² LED Panel Mount Touch Monitor
IDS-3210P-50XGA1	10.4" XGA Panel Mount Touch Monitor, 500 nits, w/ P-cap
IDS-3210G-50XGA1	10.4" XGA Panel Mount Monitor, 500 nits
IDS-3210R-50XGA1	10.4" XGA Panel Mount Touch Monitor, 500nits, w/Res.TS
IDS-3210EG-23SVA1E	10.4" SVGA 230 cd/m ² LED Panel Mount Monitor
IDS-3210ER-23SVA1E	10.4" SVGA 230 cd/m ² LED Panel Mount Touch Monitor

Optional Items

Part Number	Description
1700001524	3-pin power cord (US)
170203183C	3-pin power cord (EU)
1700008921	3-pin power cord with PSE (Japan)
96PSA-A36W12R1-3	Adapter 100-240V 36W 12V 3A
1700000243-11	M cable DVI 19P(M)/DVI 19P(M) 191cm
1700091800	Cable 9P/9P 1.8M M/F (Touchscreen RS-232 cable)

IO view

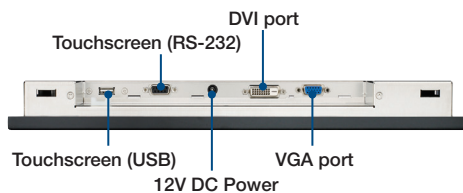

* RS-232 only is for models with resistive touch screen

Rear View

