

IDS-3106

6.5" VGA Industrial Open Frame Monitor

NEW

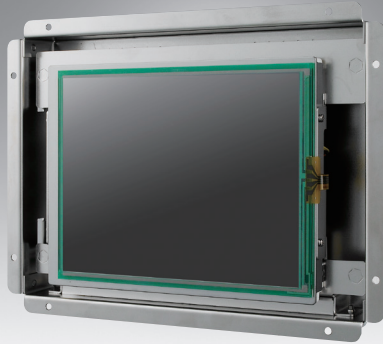

Features

- 6.5" VGA LCD panel with LED backlight for 20% power saving and environmental protection
- 0° C ~ +50° C range operating temperature
- 4-wire resistive touchscreen solution
- USB touch interface
- Dual signal interface with VGA & DVI
- Integrated bracket for easy installation
- Versatile mounting method for rear mounting and VESA mounting
- Anti-reflective treatment for sunlight readable enhancement (optional)

Introduction

The Advantech IDS-3106 Embedded Open Frame Monitor series offers flexible options for LCD, touchscreen, signal interface and chassis mounting. The series supports rear and VESA mounting. The integrated brackets bring the benefits of easy installation and provide flexibility for different applications.

Specifications

Display	Model	IDS-3106
	Size	6.5" LED panel
	Resolution	640 x 480 (VGA)
	Viewing Angle	80°/80° (H), 30°/70° (V)
	Brightness	800 (cd/m ²)
	Color Support	16.2M/262K colors
	Contrast Ratio	600:1
	Response Time	25 [msec]
	Backlight Life (hrs)	50,000 hrs
Touchscreen	T/S Type	4-Wire Resistive Touch Screen
	Surface Hardness	3H
	Durability	1 million touches
	Transparency	80% ± 3%
Environment	Operating Temperature	0~ 50° C (32 ~ 122° F)
	Storage Temperature	-20 ~ 60° C (-4 ~ 140° F)
	Humidity	5 ~ 95% @ 40° C, non-condensing
	Vibration	5-500Hz, 0.026G ² /Hz, 2.16Grms, X, Y, Z 1 hour per axis
System	I/O	VGA x1; DVI-D x 1; 12 V _{DC} Jack x 1; USB x 1 (USB is reserved for the connection to enable touch usage only)
	OSD	Keys: Menu, Up, Down, Auto Adjust, Monitor Power on/off Menu Functions: Brightness, Contrast, Screen Setting, Color Temp, Language OSD Settings, VGA/DVI, Recall, Auto Adjust.
	Power	36 W power adapter, with AC 100 ~ 240 V input and DC +12V @ 3 A output
	EMC Compliance	CE/FCC/CCC

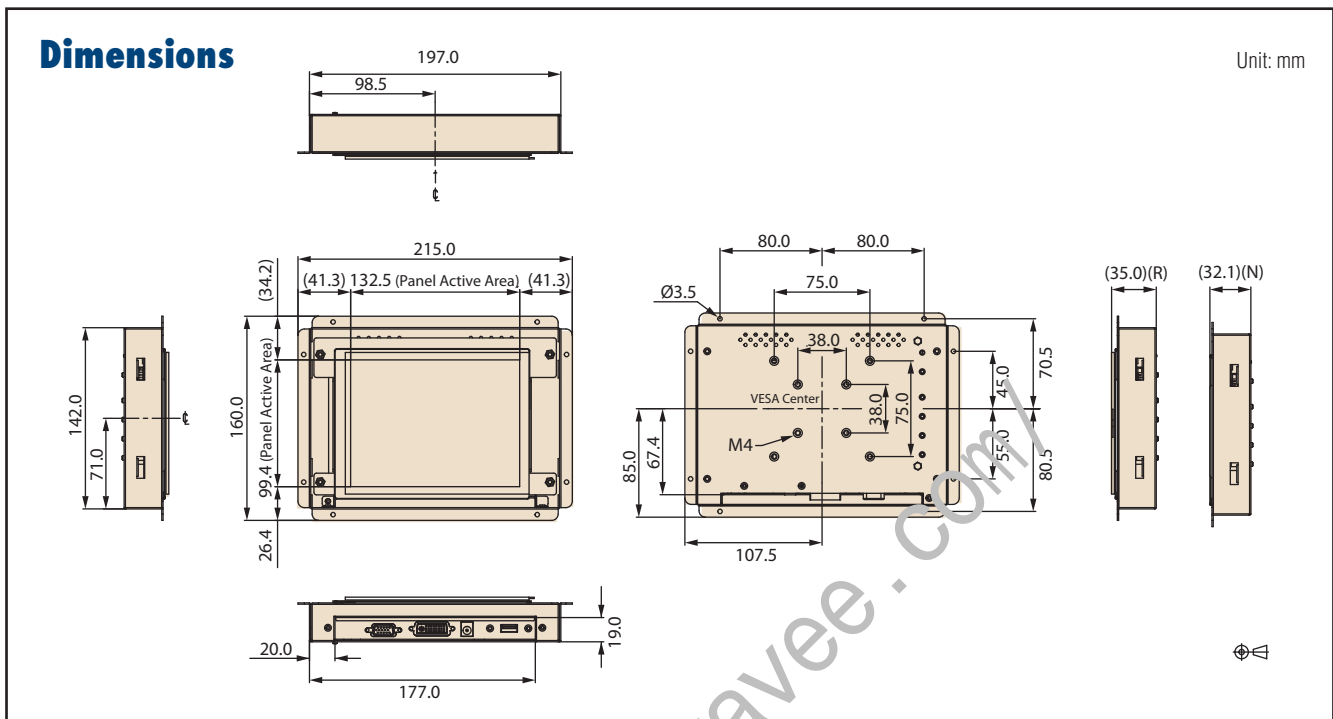

Packing List

Part Number	Description
1700002215	1 x M Cable USB-A(M)/USB-A(M) 180 CM
1700021332-01	1 x VGA cable 15P(M) 1.8 meter
1962055040	4 x Clamper
1935042520	4 x Screw of clamper M4_25L

* USB Cable is only included in IDS-3106R series.
 Note: Package contents are subject to change without prior notice

Optional Items

Part Number	Description
1700001524	3-Pin Power Cord (USA)
170203183C	3-Pin Power Cord (EU)
1700008921	3-Pin Power Cord with PSE (Japan)
96PSA-A36W12R1-3	Adaptor AC100-240V 36W +12V/3A
1700000243-11	M cable DVI 19P(M)/DVI 19P(M) 191cm

Ordering Information

Model Name	Description
IDS-3106N-80VGA1E	6.5" VGA 800cd/m ² LED Open Frame Monitor
IDS-3106R-80VGA1E	6.5" VGA 800cd/m ² LED Open Frame Touch Monitor

For more compatible embedded board solution, please visit our Build Your display web page as bellow
<http://www.advantech.com/buildyourdisplay>