

# IDK-1119

## 19" SXGA Industrial Display kit with Touch Solution

NEW

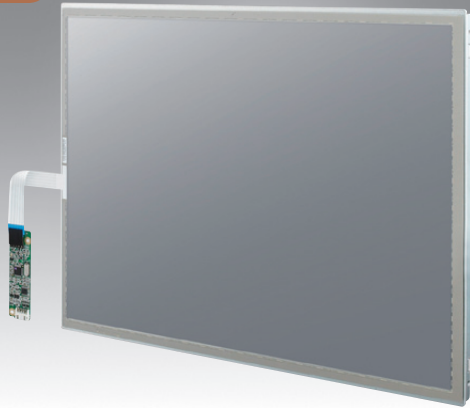

### Features

- 19" LCD supports 1280 x 1024 pixels and wide operating temperature (0 ~ 50° C)
- Brightness of 350 cd/m<sup>2</sup> with LED backlight
- 5-wire resistive touch solution
- High contrast ratio of 1000:1
- High uniformity of 80%
- LVDS signal interface
- Low power consumption 20.55 W (panel only)
- LED driver board built in
- Touch controller included (USB)
- AR surface treatment (optional)
- Optical bonding (optional)

### Introduction

The Advantech IDK-1119 series comes with a 19" industrial grade LCD display with 5-wire resistive touch. The series is also available with flexible options for LCD screens enhanced treatment such as Anti Reflection surface treatment and optical bonding solution. IDK-1119 series supports 5-wire resistive touch with low power consumption at the maximum of 20.55W. IDK-1119 series is ideal for embedded applications which customers have maximum flexibility for mechanical design.

### Specifications

LCD Panel	Display Size	19" LED backlight panel
	Resolution	1280 x 1024
	Viewing Angle (U/D/L/R)	80° / 80° / 80° / 85°
	Brightness	350 cd/m <sup>2</sup>
	Backlight Life (hrs)	50,000 hrs
	Contrast Ratio	1000 : 1
	Response Time (ms)	5 ms
	Colors	6 Bit + HiFRC (16.7 M)
	Voltage	5.0 V Power
	Consumption	20.55 W
	Signal Interface	2 channel LVDS
	Weight	2750 g
	Dimensions (W x H x D)	396 x 324 x 20.7 mm
Touch Screen	Touch Screen	5-wire Resistive
	Transparency	80± 3%
	Surface Hardness	3H
	Durability	10 million times
Environment	Operating Temperature	0 ~ 50° C
	Storage Temperature	-20 ~ 60° C
	Humidity	5 ~ 90% @ 25° C, non-condensing

## Dimensions

Unit: mm

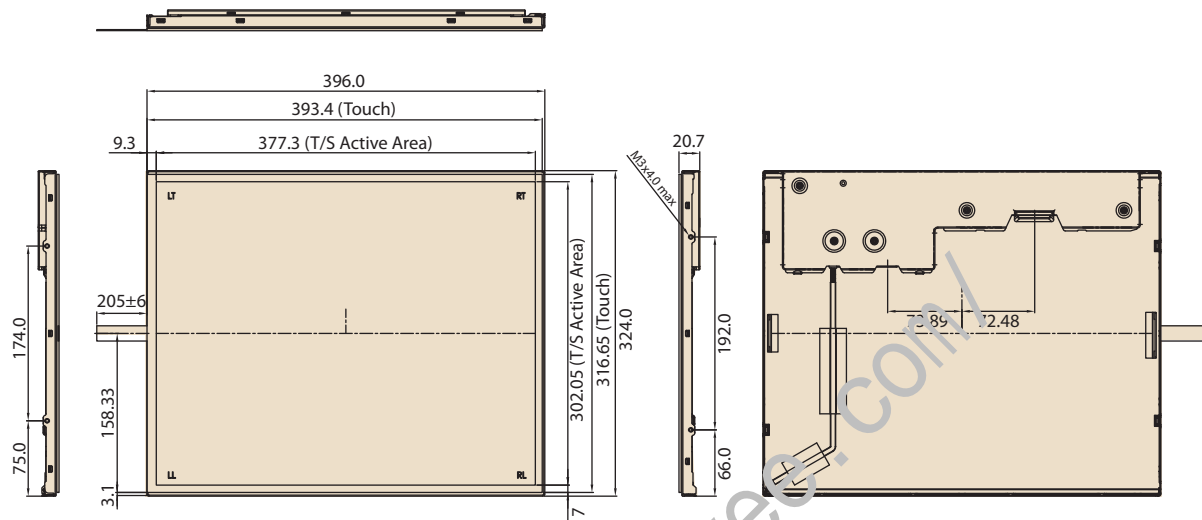

## Ordering Information

Part No.	Size	Brightness (cd/m <sup>2</sup> )	Interface	Touch screen	Touch Interface
IDK-1119R-35SXA1E	19"	350	LVDS	5-wire Resistive	RS-232/USB

## Packing List

Part Number	Description
ETM-RES04C-EEH4EE	1 x 5-wire Touch controller
1700020324-01	1 x USB Touch cable 5P-2.C/USB-A (M) 180CM

Note: Package contents are subject to change without prior notice

## Optional Order

SBC Part No.	LVDS Cable Part No.	Display Interface	B/L Cable Part No.	Touch Interface	Touch Power Input
MIO-5270	96CB-L3040PAF5	LVDS: Dual channel 24bit (SXGA)	96CB-E0905PAF3 (12V: PWM)	USB	5 V
AIMB-270	96CB-L3040PAF5	LVDS: Dual channel 24bit (SXGA)	96CB-E0905PAF3 (12V: PWM)	USB	5 V

For more compatible embedded board solution, please visit our Build Your display web page as bellow  
<http://www.advantech.com/buildyourdisplay>